

Small & medium capacity air pump

HP-40 / 60 / 80



Pressure type

Outdoor (Rainproof) use

Applications

- Low frequency therapeutic equipment and other medical & scientific apparatus
- Septic tank (biological contact aeration)
- Bubble bath (air bubble injection)
- Oxygen supply for fish breeding

Dimensions

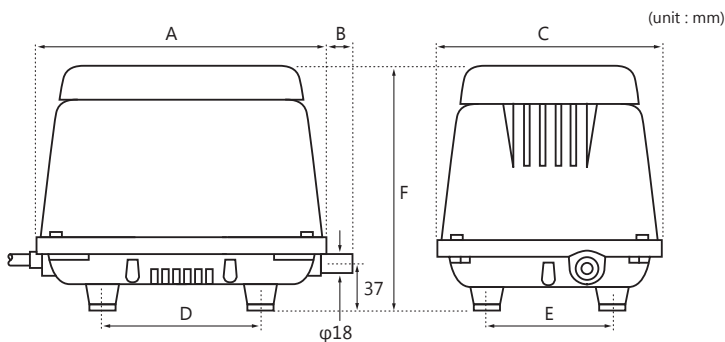

TYPE	A	B	C	D	E	F
HP-40	208	20	171	120	90	190
HP-60/80	235	21	180	130	100	196

Specifications

	HP-40	HP-60	HP-80
Rated voltage [V]	AC120 / 230		
Power frequency [Hz]	50 60	50 60	50 60
Rated pressure [kPa]	12.8	14.7	
Airflow volume [L/min]	40	60	80
Power consumption [W]	38	51	71
Sound level [dBA]	32	35	36
Weight [kg]	5.7	7	

Performance Curve

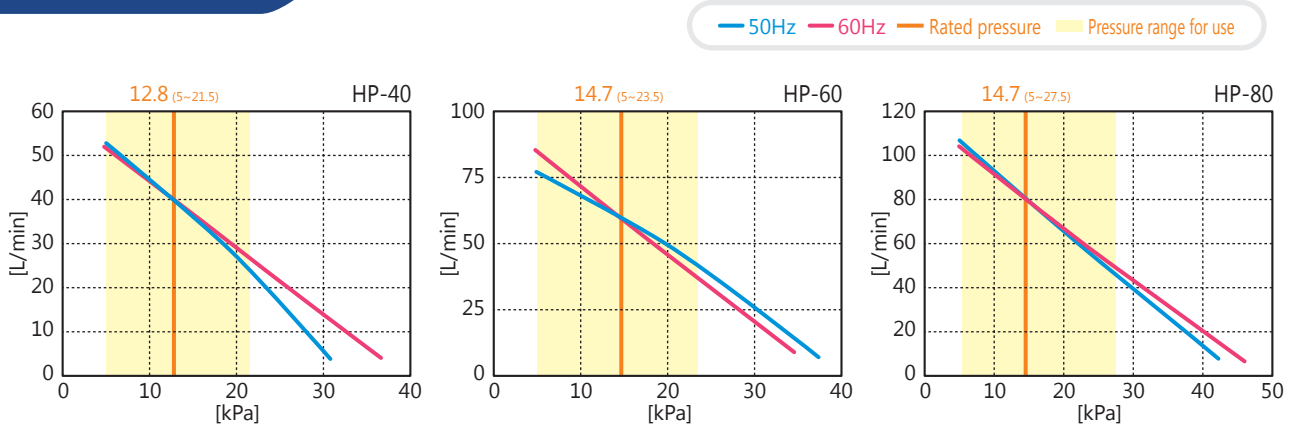

* All characteristics values are only for reference, and are not guaranteed values.
* Note that the operating temperature for our pumps is 41°F(5°C) to 104°F(40°C).